



Static Grounding Reels

**Aircraft Refueling • Chemical Plants • Grain Elevators
Rescue and Hazmat Operations**

Note to designers and Engineers.

Static Grounding Reels

Hose & Reel Products static grounding reels provide for the payout, retraction and compact storage capacities of up to 200 feet of grounding cable. These spring rewind reels are used in any flammable atmosphere where a build-up of static electricity could cause a spark and subsequent explosion.

**These reels are for Static Grounding ONLY.
NOT intended for lightning protection!**

Contents

Reel Type	Page
Static grounding Reels for refueling or hazardous areas	
HRP1140-1141	3
HRP1144	4
HRP1145	5

Static grounding Reels for refueling or hazardous areas.

For Aircraft Refueling, Chemical Plants, Grain Elevators, Rescue and Hazmat Operations

Hose & Reel Products static grounding reels provide for the payout, retraction and compact storage capacities of up to 61m of grounding cable. These spring rewind reels are used in any flammable atmosphere where a build-up of static electricity could cause a spark and subsequent explosion. They bond and/or ground aircraft, fuel trucks and other equipment during refueling or other hazardous operations. Their spring motors provide smooth operation and require minimum cable pull to release the lock. A declutching arbor automatically disengages the spring to prevent damage from reverse winding. All models have an adjustable guide arm with cable guide to prevent cable build-up during rewinding. The arm can be locked in any operating position in a 270° arc. Static grounding reels for refueling or hazardous areas.

HRP1140-1141

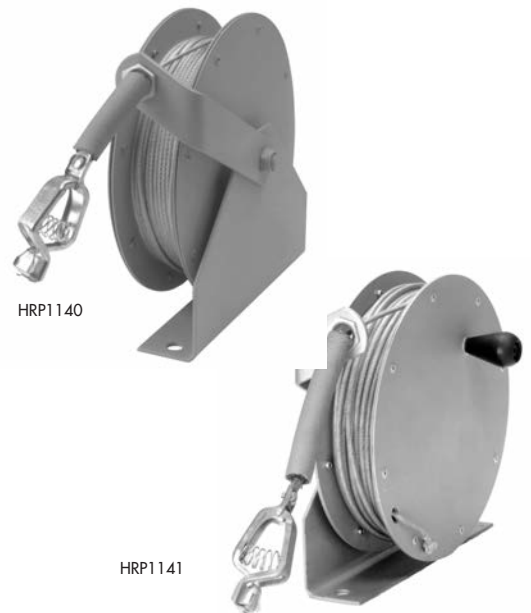

Series HRP1140-1141

- These reels bond and/or ground aircraft, fuel trucks, and other equipment.
- Provide smooth operation and require minimum cable pull.
- Declutching arbor and adjustable guide arm with cable guide.
- Standard finish is oven-cured enamel.
- Manual rewind version also available.
- All shown with optional cable and/or "Y" branch
- Available with 1/8", 7x19 galvanized carbon steel cable.

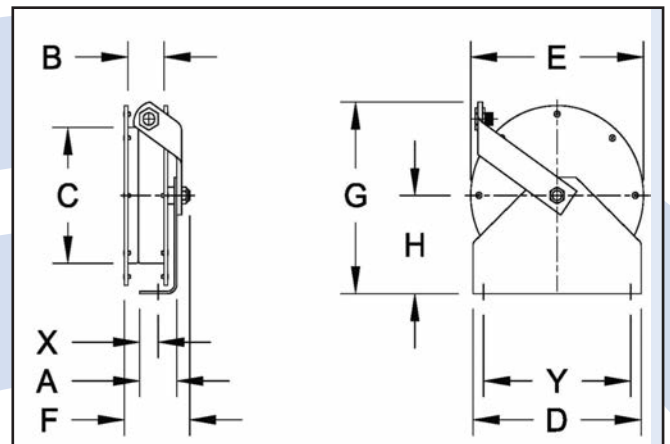

HRP1140-1141 - Static grounding Reels

Model Number	Cable Capacity (m)	Approx. Weight (kg) with cable	Reel Dimensions (mm)									
			A	B	C	D	E	F	G	H	X	Y
HRP1140	22,9	5	51	51	178	229	235	89	251	129	25	200
HRP1141	30,5	5	51	51	178	229	235	133	251	129	25	200

- 100 amp alligator clamp.
- Stainless steel or plastic-covered cable and "Y" branches available at additional charge.

1. Specifications subject to change.
2. To order, specify gauge, length, O.D., and coating, if required.
3. Specify "Y" branch, if required.
4. Specify complete model number.

Series HRP1140

Models HRP1144 are available with 1/8", 7x19 galvanized carbon steel cable with 100 amp Alligator Clamp as standard. Stainless steel or plastic-covered cable and "Y" branches are available at an additional charge. A nonsparking ratchet assembly locks the reel when the desired length of cable has been payed out. These heavy-duty reels are repairable and parts are readily available. They hold large capacities of cable and are ideal for industrial and mobile hard duty applications. Standard finish is oven-cured enamel. Also available, manual rewind version. For a detailed parts breakdown drawing, request ISO 10.

HRP1144



Notes:

- To Order (specify all items listed):
1. Gauge, length, O.D., and coating if required
 2. Specify "Y" branch if required
 3. Finish if other than standard
 4. Complete model number
 5. Reels are UPS shippable.
 6. Accessory seperated.
 7. Specifications subject to change.

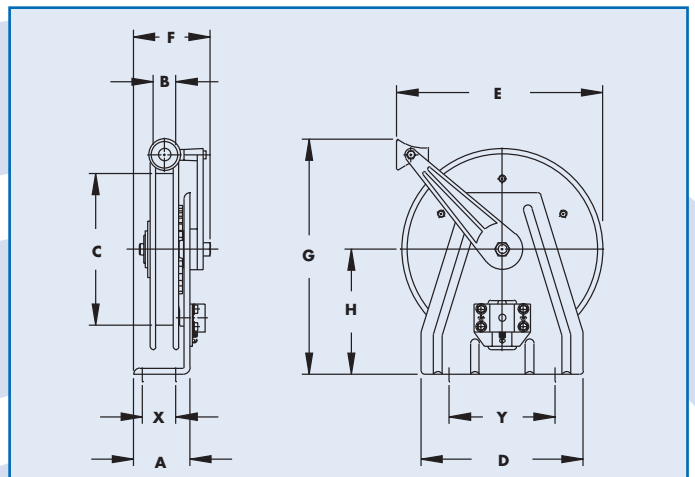

HRP1144 - Static grounding Reels

Model Number	Cable Capacity (m)	Approx. Weight (kg) with cable	Reel Dimensions (mm)									
			A	B	C	D	E	F	G	H	X	Y
HRP1144	30	19	102	32	337	292	425	140	451	226	60	191

Series HRP-1145
For Grounding in Hazardous Areas

- These reels bond and/or ground aircraft, fuel trucks, and other equipment.
- Provide smooth operation and require minimum cable pull.
- Declutching arbor and adjustable guide arm with cable guide.
- Optional stainless steel construction of spool, frame, and ratchet system available.
- Standard finish is oven-cured enamel.
- Manual rewind version also available.
- Available with 1/8", 7x19 galvanized carbon steel cable.
- 100 amp alligator clamp.
- Stainless steel or plastic-covered cable and "Y" branches available at additional charge.
- Cable guide arm of cast aluminum and ZA12 aluminum alloy.

HRP 1145



Notes:

1. Specifications subject to change.
2. To order, specify gauge, length, O.D., and coating, if required.
3. Specify "Y" branch, if required.
4. Specify complete model number.

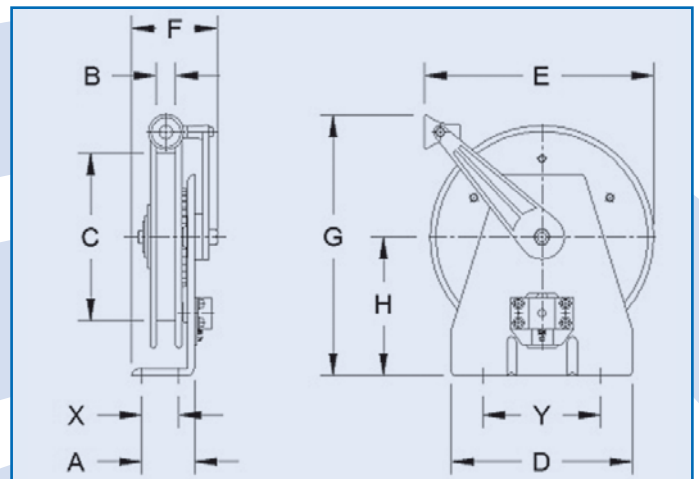

HRP1145 - Static grounding Reels

Model Number	Cable Capacity (m)	Approx. Weight (kg) with cable	Reel Dimensions (mm)									
			A	B	C	D	E	F	G	H	X	Y
HRP1145	30	16	102	32	337	292	425	140	451	226	60	191